

Safetygram-1

Gaseous Oxygen

General

Oxygen is the second largest component of the atmosphere, comprising 20.8% by volume. Gaseous oxygen is colorless, odorless, tasteless, and nonflammable. Oxygen is necessary to support life. It is a strong oxidizer that combines readily with many elements to form an oxide and is necessary to support combustion.

Oxygen will react with nearly all organic materials and metals. Materials that burn easily in air will burn more vigorously in oxygen. Equipment used in oxygen service must meet stringent cleaning requirements; any system must be constructed of materials that have high ignition temperatures and which are nonreactive with oxygen under the service conditions. Vessels should be manufactured to American Society of Mechanical Engineers (ASME) codes and designed to withstand the temperatures and pressures involved.

Manufacture

Oxygen is produced by an air separation unit (ASU) through the liquefaction of atmospheric air and separation of the oxygen by continuous cryogenic distillation. The oxygen is then removed and stored as a cryogenic liquid. Oxygen can also be produced noncryogenically using selective adsorption processes to produce gaseous product.

The ASU manufacturing process begins with a main air compressor and ends at the output of the product storage tanks. Air is compressed and sent through a clean-up system where moisture, carbon dioxide, and hydrocarbons are removed. The air then passes through heat exchangers where it is cooled to cryogenic temperature. Next, the air enters a high pressure distillation column where it is physically separated into a vaporous form of nitrogen at the top of the column and a liquid form of "crude" oxygen (~90% O₂) at the bottom.

This crude oxygen liquid is withdrawn from the column and sent to a low-pressure column where it is distilled until it meets commercial specifications. The liquid oxygen is sent to a cryogenic storage tank.

Noncryogenic methods of air separation contain some of the same unit processes such as compression and clean-up, but differ in the fundamental technology to separate air into its components. Oxygen can be separated from nitrogen using Pressure/Vacuum Swing Adsorption (PSA/VSA) technology. Adsorption relies on a material (zeolite) that has the property of selectively adsorbing nitrogen while under a slight pressure and allowing oxygen to pass through. The adsorbed nitrogen is released from the zeolite by dropping the pressure to a lower level (often under vacuum) during the PSA/VSA process. When oxygen is produced by adsorption, argon flows through with the oxygen, producing oxygen with a purity range of 90-95%.

Uses

Oxygen is generally liquefied so it can be more effectively transported and stored in large volumes. However, most applications use oxygen in the gaseous form. The primary uses of oxygen relate to its strong oxidizing and life-sustaining properties. Oxygen is commonly relied upon in health and medical applications. Liquid oxygen is used as an oxidant for liquid fuels in the propellant systems of missiles and rockets.



Oxygen is widely applied in the metal industries in conjunction with acetylene and other fuel gases for metal cutting, welding, scarfing, hardening, cleaning, and melting. Steel and iron manufacturers also extensively use oxygen or oxygen-enriched air to affect chemical refining and heating associated with carbon removal and other oxidation reactions. Benefits such as fuel and energy savings plus lower total emission volumes are realized when air is enriched or replaced with higher-purity oxygen.

In the chemical and petroleum industries, oxygen is used as a feed component to react with hydrocarbon building blocks to produce chemicals such as alcohols and aldehydes that contain oxygen in their structure. In many processes, the oxygen for reaction can be obtained from the use of air. However, direct use of oxygen, or enrichment of the air with oxygen, is necessary for some processes. There are several major petrochemical intermediates that are presently manufactured with high-purity oxygen including ethylene and propylene oxide (antifreeze), vinyl chloride (for PVC), and caprolactam (for nylon).

The pulp and paper industry uses oxygen as a bleaching and oxidizing agent. A variety of process (liquor) streams show enhanced physical properties after treatment with oxygen; plant operating costs also improve.

Similarly, oxygen enhances the combustion process in industries that manufacture glass, aluminum, copper, gold, lead, and cement or that are involved in waste incineration or remediation. There are corresponding productivity, energy, maintenance, and emissions benefits end-users may realize.

Wastewater treatment plants successfully employ oxygen to enhance their chemical process efficiency. Aquaculturists such as fish-farmers also see benefits in the health or size of their livestock when the host environment is oxygenated.

Table 1: Gaseous Oxygen Physical and Chemical Properties

Chemical Formula	O ₂
Molecular Weight	31.999
Boiling Point @ 1 atm	-297.4°F (-183.0°C)
Freezing Point @ 1 atm	-361.9°F (-218.8°C)
Critical Temperature	-181.8°F (-118.4°C)
Critical Pressure	729.1 psia (49.6 atm)
Density, Liquid, @ BP, 1 atm	71.23 lb/scf
Density, Gas @ 68°F (20°C), 1 atm	0.0831 lb/scf
Specific Gravity, Gas (air=1) @ 68°F (20°C), 1 atm	1.11
Specific Volume @ 68°F (20°C), 1 atm	12.08 scf/lb
Latent Heat of Vaporization	2934 Btu/lb mole
Expansion Ratio, Liquid to Gas, BP to 68°F (20°C)	1 to 860
Solubility in Water @ 77°F (25°C), 1 atm	3.16% by volume

Health Effects

Normally air contains 21% oxygen and oxygen is essentially nontoxic. No health effects have been observed in people exposed to concentrations up to 50% at 1 atmosphere for 24 hours or longer.

The inhalation at 1 atmosphere of 80% oxygen for more than 12 hours can cause irritation of the respiratory tract, progressive decrease in vital capacity, coughing, nasal stuffiness, sore throat, and chest pain, followed by tracheobronchitis and later by pulmonary congestion/edema.

Inhalation of pure oxygen at atmospheric pressure or less can cause pulmonary irritation and edema after 24 hours.

Respiratory symptoms can occur in two to six hours at pressures above 1 atmosphere. One of the earliest responses of the lung is accumulation of water in the interstitial spaces and within the pulmonary cells. This can cause reduced lung function, which is the earliest measurable sign of toxicity. Other symptoms include fever, and sinus and eye irritation.

When pure oxygen is inhaled at pressures greater than 2 or 3 atmospheres, a characteristic neurological syndrome can be observed. Signs and symptoms include nausea, dizziness, vomiting, tiredness, light-headedness, mood changes, euphoria, confusion, incoordination, muscular twitching, burning/tingling sensations particularly of the fingers and toes, and loss of consciousness. Characteristic epileptic-like convulsions, which may be

preceded by visual disturbances, such as loss of peripheral vision, also occur. Continued exposure can cause severe convulsions that can lead to death. The effects are reversible after reduction of oxygen pressure.

Premature infants placed in incubators to breathe oxygen in concentrations greater than in air can develop irreversible eye damage. Within six hours after an infant is placed in a high-oxygen atmosphere, vasoconstriction of the immature vessels of the retina occurs, which is reversible if the child is immediately returned to air but irreversible if oxygen-rich therapy is continued. Fully developed blood vessels are not sensitive to oxygen toxicity.

Containers

Gaseous oxygen is shipped and stored in high-pressure cylinders, tubes, or tube trailers depending on the quantity required by the user. Cylinders are designed and manufactured according to applicable codes and specifications for the pressures and temperatures involved. Cylinders are manufactured according to Department of Transportation (DOT) regulations, which specify the material of construction, method of manufacture, testing, and what products they are permitted to be filled, as well as other details. The quantity of product a container can hold is determined by its pressure rating and internal volume. Generally the higher the pressure, the more oxygen is contained in a cylinder.

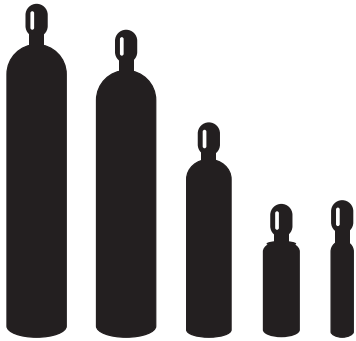

Fig. 1 Typical cylinder shapes and sizes.

Cylinders

A cylinder is a hollow tube with a closed concave base that permits it to stand upright. The opposite end is tapered to a small opening that is threaded to accommodate the installation of a valve. A threaded neck ring is attached to the tapered end so that a protective cylinder cap can be installed.

Cylinders may be used individually or in groups. When used in groups, the cylinders should be piped together, for either stationary storage or to form portable banks.

Tubes

A tube is a pipe tapered at both ends. Each end is threaded to allow the installation of valves, connections, or relief devices.

Tubes are manufactured according to DOT regulations or they may be made to ASME codes, depending upon whether they are used for transportation or mounted permanently at a site. Tubes are generally mounted on a truck-trailer chassis or railcar bed, or placed at stationary locations when large amounts of oxygen are needed.

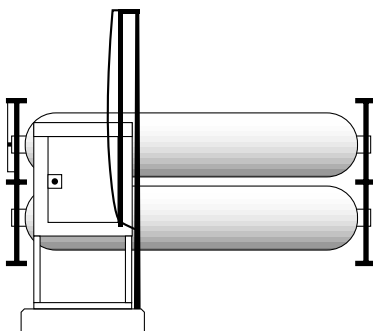

Fig. 2 A typical tube container system for gaseous oxygen.

1. Cylinder Specification

- DOT—Department of Transportation, which is the regulatory body that governs the use of cylinders.
- Specification of the cylinder type or material of construction (e.g., 3AA).
- Service or working pressure in pounds per square inch (e.g., 2,265 psi)

2. Cylinder Serial Number

- The letters SG precede the serial numbers for Specialty Gas cylinders.

3. Registered Owner Symbol

- Symbol used to indicate the original owner of the cylinders.
- APROINC is a Registered Owner Symbol for Air Products.

4. Date of Manufacture

- This date (month-year) also indicates the original hydrostatic test.

5. Neck Ring Identification

- The cylinder neck ring displays the name of the current owner of the cylinder.

6. Retest Markings

- The format for a retest marking is: Month–Facility–Year–Plus Rating–Star Stamp.
- The + symbol (Plus Rating) indicates that the cylinder qualifies for 10% overfill.
- The ★ symbol (Star Stamp) indicates that the cylinder meets the requirements for 10-year retest.

7. CylinderTrak™ Bar Code Label

- The CylinderTrak bar code label provides a unique cylinder identifier and is used by computer systems to track cylinders throughout the fill process. As an optional service, we have the capability of tracking cylinders to and from customers.

8. Cylinder Manufacturer's Inspection Marking

9. Cylinder Tare (Empty) Weight

Fig. 3 Key to cylinder stampings.

Valve Connections

The Compressed Gas Association (CGA) recommends three different connections for oxygen depending on the pressure of the container.

In addition, a high-integrity connection also known as a Diameter Index Safety System (DISS) connection has been assigned to oxygen service; medical post-type valves are assigned a yoke connection. See Table 2 for details. For detailed drawings of these connections consult CGA Pamphlet V-1. For general drawings consult the Air Products "Specialty Gases and Equipment Catalog."

WARNING: NEVER use adapters to make cylinder connections!!!

Cylinder Service	CGA Connection
Oxygen < 3000 psig	540
Oxygen at 3001 to 4000 psig	577
Oxygen at 4001 to 5500 psig	701
Medical oxygen with post valve	870
Semiconductor	714

Pressure-Relief Devices

Oxygen containers are equipped with pressure-relief devices to protect from overpressurization and possible rupture. Cylinders less than 65" long use a rupture disk device. Cylinders over 65" use a combination device consisting of a rupture disk backed by a fusible alloy. Combination devices require that both the temperature and pressure requirements be reached before the device will relieve. For more information on pressure-relief devices consult Air Products' Safetygram-15, "Cylinder Pressure-Relief Devices."

Container Stampings

Each cylinder or tube is identified by stampings in the metal of the shoulder. Fig. 3 depicts an example of these stampings and what they mean.

Shipment of Gaseous Oxygen

All shipments of compressed oxygen must comply with DOT regulations. This applies to motor freight, rail, air, and water shipments. For air shipments, all packages must also comply with International Air Transport Association / International Civil Air Organization (IATA/ICAO) Dangerous Goods regulations. Water vessel shipments must also be prepared in accordance with the International Maritime Organization (IMO) regulations. All packaging used to transport oxygen must be either "UN/DOT Specification" or "UN/DOT Authorized" and in proper condition for transport. DOT Code of Federal Regulations, Title 49, also specifies the following labeling and identification requirements:

DOT Shipping Name: Oxygen, Compressed

DOT Hazard Class: 2.2

DOT Shipping Label: Nonflammable Gas and Oxidizer (For domestic shipments only the oxygen label may be used)

Identification Number: UN1072



Fig. 4 Oxygen shipping label.

Safety Considerations

Fire is the primary hazard associated with gaseous oxygen. Although nonflammable, oxygen readily supports combustion. Explosions may occur in locations where a mixture of fuel gas and oxygen can accumulate.

It is important to note that fire chemistry starts to change in oxygen-enriched environments. The CGA has established the definition of an oxygen-enriched atmosphere as being any atmosphere containing at least 23% oxygen. Materials easily ignited in air not only become more susceptible to ignition, but also burn with added violence. These materials include clothing and hair, which have air spaces that readily trap oxygen. Oxygen levels of 23% can be reached very quickly and all personnel must be aware of the hazard.

Systems used in oxygen service must meet stringent cleaning requirements to eliminate any incompatible contaminants. CGA Pamphlet G-4.1, "Cleaning Equipment for Oxygen Service," describes cleaning methods for equipment used in oxygen service and CGA Pamphlet O2-DIR, "Directory of Cleaning Agents for Oxygen Service," provides comparative information on cleaning agents used to clean oxygen equipment. Also, review the appropriate Material Safety Data Sheet (MSDS).

Buildings

Adequate ventilation must be provided in areas where oxygen is in use. Keep them clear of combustible materials and post signs indicating the hazard. Also post "No Smoking" signs. Test the atmospheres in confined work areas for oxygen content. Oxygen-enriched atmospheres can cause materials that burn in air to burn more violently or even explosively. Oxygen concentrations in excess of 23% increase the hazard exposure to personnel and material.

Remember, oxygen has no warning properties!

Storage

- Cylinders should be stored upright in a well-ventilated, dry, cool, and preferably fire-resistant, secure area, which is protected from the weather.
- Storage temperatures should **NEVER** exceed 125°F (52°C) and the area should be free of combustible materials. Storage should be away from heavily traveled areas and emergency exits.
- Oxygen must be separated from flammables and combustibles by 20 feet or a half-hour fire wall.
- Post "No Smoking" and "No Open Flames" signs. Copies of signs may be downloaded from Air Products' Product Stewardship web site at www.airproducts.com/productstewardship.
- Avoid areas where salt or other corrosive materials are present. Valve protection caps and valve outlet seals should remain on cylinders not connected for use.
- Separate full from empty cylinders. Avoid excessive inventory or storage time and keep good inventory records.
- Use a first-in first-out (FIFO) system.

Handling

- Use only oxygen compatible lubricants.
- If you experience any difficulty operating the container valve or with the container connections, discontinue use and contact the supplier. Use the proper connections.
- **DO NOT USE ADAPTERS!**
- Do not remove or interchange connections.
- Use piping and equipment designed to withstand pressures to be encountered.
- It is recommended that all vents be piped to the exterior of the building.

- Use a suitable handtruck designed for cylinder movement. Do not drag, roll, or slide containers on their sides.
- Never attempt to lift a cylinder by its cap.
- Secure cylinders at all times while in use.
- Use a pressure reducing regulator or separate control valve to safely discharge gas from cylinder.
- Use a check valve to prevent reverse flow into the cylinder.
- Do not overheat cylinder to increase pressure or discharge rate.
- **NEVER** insert an object (e.g., wrench, screwdriver, pry bar, etc.) into valve cap openings. Doing so may damage the valve causing it to leak.
- Use a special cap wrench or adjustable strap-wrench to remove overtightened or rusted caps.

Refilling or shipping compressed gas cylinders without the consent of the owner is a violation of Federal law.

Personal Protective Equipment (PPE)

Personnel must be thoroughly familiar with properties and safety considerations before being allowed to handle oxygen and its associated equipment. Safety glasses, safety shoes, and leather work gloves are recommended when handling cylinders.

Only trained and certified emergency responders should respond to emergency situations. In emergency situations, self-contained breathing apparatus (SCBA) must be used. Clothing which is fire-resistant in air may be readily ignitable in oxygen-enriched atmospheres.

First Aid

When breathing oxygen mixtures are used at pressures above 1 atmosphere, seek medical advice for proper health instructions.

Fighting Fires

Since oxygen is nonflammable, but supports combustion, fire-fighting actions require shutting off the source of oxygen, if possible, then fighting the fire according to the material involved. Most cylinders are designed to vent contents when exposed to elevated temperatures. However, upon exposure to intense heat or flame, a cylinder may vent rapidly and/or rupture violently.

Emergency Response System

- Call: **+1 (800) 523-9374** (Continental U.S. and Puerto Rico)
- Call: **+1 (610) 481-7711** (Other locations)
- 24 hours a day, 7 days a week
- For assistance involving Air Products and Chemicals, Inc. gases and equipment.

Product Safety Information

- For MSDS and Safetygrams:
www.airproducts.com/productstewardship
- Fax-on-Demand:
Call: **+1 (800) 245-2746**
- Enter MSDS Index No. 1000 for a complete list of available safety literature.
- 24 hours a day, 7 days a week

Technical Information Center

- Call: **+1 (800) 752-1597** (U.S.)
- Call: **+1 (610) 481-8565** (Other locations)
- Fax: **+1 (610) 481-8690**
- E-mail: **gasinfo@apci.com**
- Monday–Friday, 8:00 a.m.–5:00 p.m. EST

Information Sources

- Compressed Gas Association
1725 Jefferson Davis Highway, Suite 1004
Arlington, VA 22202-4102
Phone: +1 (703) 412-0900
- National Fire Protection Association
1 Batterymarch Park, P.O. Box 9101
Quincy, MA 02269-9101
Phone: +1 (800) 344-3555